

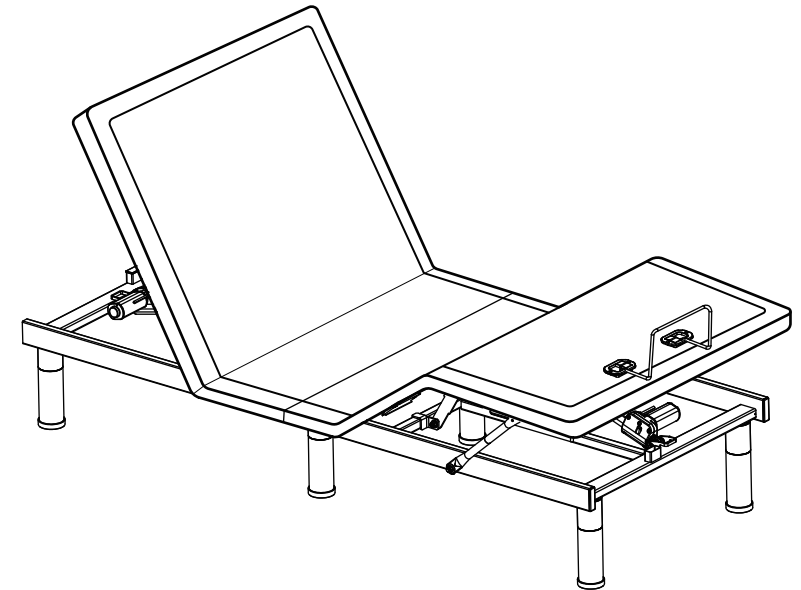

# AQUARIUS 200 SERIES

## Owner's Manual



Manufactured by Dreamotion in China  
for Crown Posture Bedding Pty. Ltd. & SlumberCorp Pty. Ltd.  
& Bedco Pty.Ltd.

2/11-15 Hardner Road, Mount Waverley, VIC 3149.  
105 Radium Street, Welshpool, WA 6106.  
113 Beatty Road, Archerfield Q 4108. Australia.

Serial No:  
All Rights Reserved.

Rev 1.0 01/2022

# CONTENTS

Safety & Warranty Warning ..... 01

Parts List ..... 02

Installation Guide ..... 03

Remote Control Guide ..... 08

APP Control Guide ..... 09

Troubleshooting ..... 10

Warranty ..... 11

## ATTENTION!

Important safety instructions. Please read these instructions thoroughly before using this product.

### IMPORTANT SAFETY INSTRUCTIONS

When using an electrical furnishing, basic precautions should always be followed, including the following:  
Read all instructions before using (this furnishing).

**DANGER** – To reduce the risk of electric shock

1. Always unplug this furnishing from the electrical outlet before cleaning or servicing

**WARNING** – To reduce the risk of burns, fire, electric shock, or injury to persons:

1. Unplug from outlet before putting on or taking off parts.
2. Close supervision is necessary when this furnishing is used by, or near children, invalids, or disabled persons.
3. Use this furnishing only for its intended use as described in these instructions. Do not use attachments not recommended by the manufacturer.
4. Never operate this furnishing if it has a damaged cord or plug, if it is not working properly, if it has been dropped or damaged, or dropped into water. Return the furnishing to a service center for examination and repair.
5. Keep the cord away from heated surfaces.
6. Do not use bed outdoors.
7. Do not use bed near explosives.
8. Using bed with oxygen administering equipment other than the nasal masked type creates a possible fire hazard.
9. Do not operate where aerosol (spray) products are being used or where oxygen is being administered.
10. To disconnect, turn all controls to the off position, then remove plug from outlet.
11. Use caution when having liquids in or around the bed to ensure no spillage occurs. In case of spillage, stand in a dry, clean area of the floor and unplug the bed immediately. Clean up spill and allow the area around bed to dry thoroughly before using the electric controls again. Do not eat or drink hot liquids while operating the bed.
12. Do not allow any person or pet under the bed at any time.
13. During bed operation, make sure body is positioned within the confines of the bed. Do not place extremities over the sides of the bed when operating bed functions.
14. Only for household and similar location use.

15. Never operate the furnishing with the air openings blocked. Keep the air openings free of lint, hair, and the like.
16. Never drop or insert any object into any opening.

### SAVE THESE INSTRUCTIONS

#### WEIGHT LIMITS:

- Weight Restrictions: The recommended weight limits on our adjustable beds is 700 pounds. The bed will structurally support this weight, provided it is evenly distributed across the foundation. The power foundation is not designed to support or lift this amount in the head or foot sections alone. Exceeding this weight restriction could damage the bed and/or cause injury and will void the warranty.

#### WARRANTY WARNINGS:

- Any opening or tampering with the control box, motors, or hand controls (with the exception of the battery compartment if equipped) will result in a void of the warranty.

#### PRODUCT RATING:

- The motors are not designed to operate continuously for more than [2] minutes in an [20] minute time period or approximately 10% duty cycle. Attempting to circumvent or exceed this rating will shorten the life expectancy of the foundation and may void the warranty.

#### OPERATING INFORMATION:

- After power foundation assembly is completed, operate remote control to ensure proper functions.
- Keep moving parts free of obstruction during bed operation (including sheets, clothing, tubing, wiring, and products using electric power cords).
- Distribute body weight evenly over bed surface. Do not place entire weight on head or foot sections of the bed, during repositioning and entering or exiting bed.

#### HOSPITAL DISCLAIMER:

- It is NOT designed for hospital use and is NOT designed to meet hospital standards.

### RADIO FREQUENCY: 2.4 GHz

#### FCC COMPLIANCE:

This device complies with Part 15 of the FCC Rules. Operation is subject to the following two conditions: (1) This device may not cause harmful interference, and (2) this device must accept any interference received, including interference that may cause undesired operation.

To comply with the FCC RF exposure requirements, no change to the antenna or the device is permitted. Any change to the antenna or the device could result in the device exceeding the RF exposure requirement and void user's right to operate the device.



## Standard Parts List



All electronics and components that need to be installed are placed in boxes under the foundation or attached to the frame. Before discarding the packing materials, ensure that all the parts are accounted for.

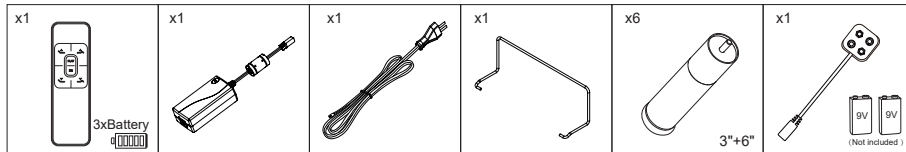

Wireless Remote

Power Supply  
(29V 2.0A)

AC Power Cord

Mattress Retainer Bar

Adjustable Legs  
3"×6"

Battery Lock Wire  
(Not included)

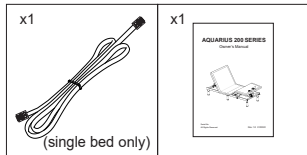

(single bed only)  
Sync Cord

Owner's Manual

## Optional Accessories (universal parts)

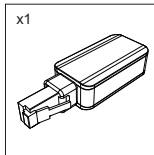

Bluetooth Receiver

## Optional Accessories (headboard bracket)

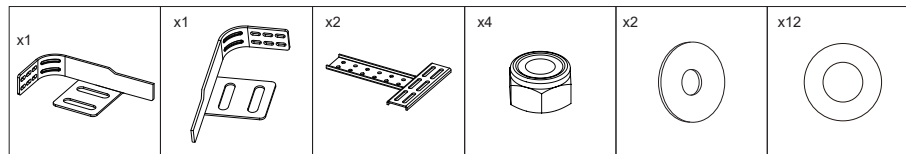

Headboard Bracket  
Mount(L)

Headboard Bracket  
Mount(R)

T-channel Assy

M8 Lock Nuts

Washers  
(d10D30t2)

Washers  
(d8.5D17t1.2)

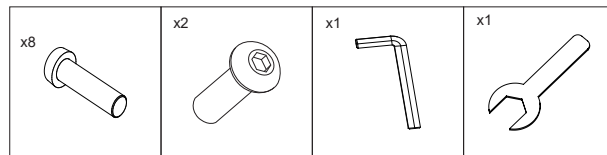

Hex Head Bolts  
(M8×20)

Hex Socket Button Head  
Screws(M10×25)

Socket Screw Wrench  
(6#)

Simple Open End  
Wrench S13

## Not Included

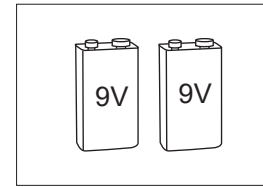

power supply with battery backup box

**NOTE:** To avoid damage to the foundation, always open the carton while the foundation is in the flat position.

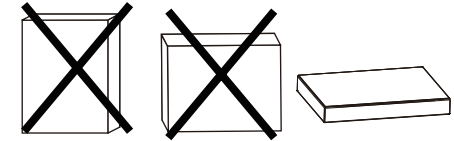

## Installation Guide

Two people are required to set up the foundation.

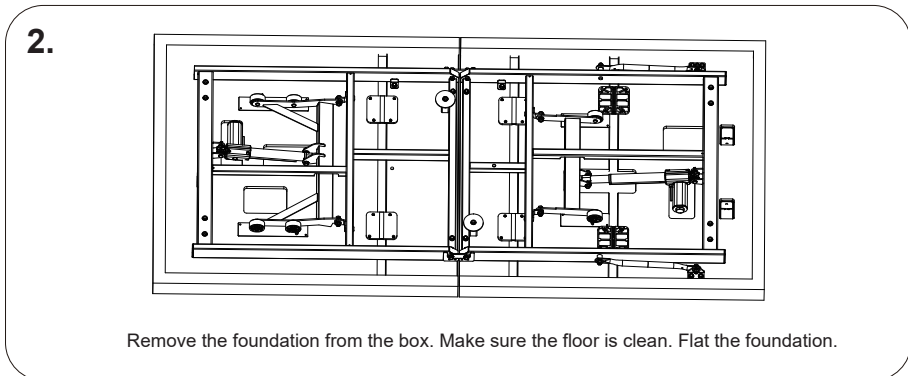
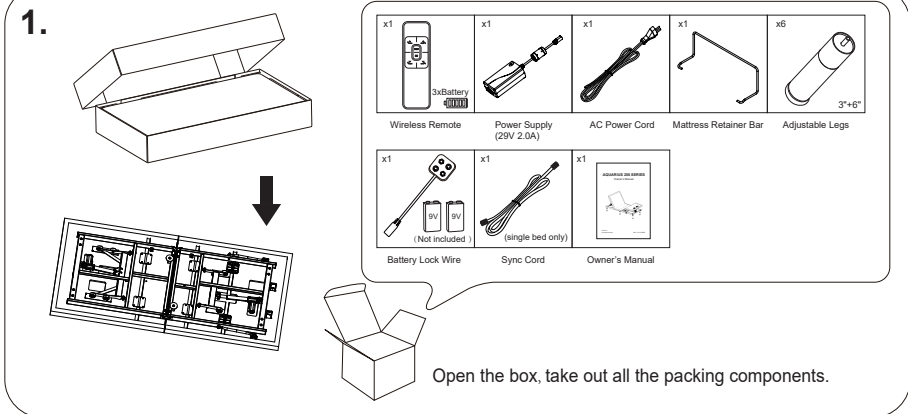

**3.** If the adjustable legs are required, please refer to below installation guide.

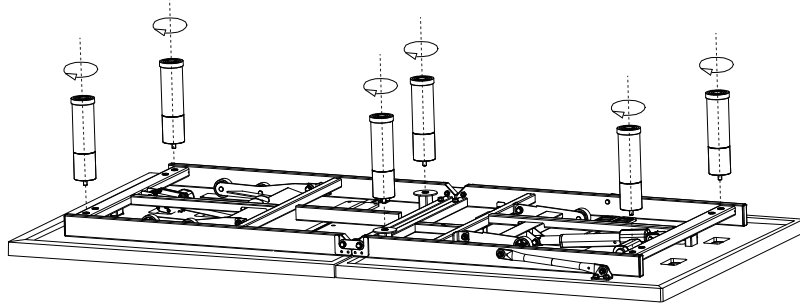

Install legs and tighten by hand.

**4.**

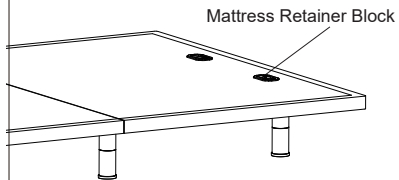

Carefully rotate the foundation over so it is resting on its legs.

**5.**

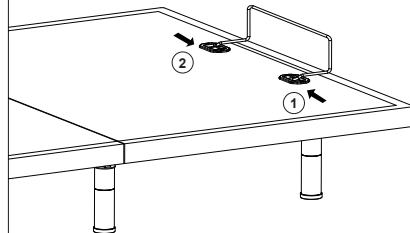

Slide the left side of the mattress retainer bar into the block. Pull the retainer bar to the opposite bracket and secure the right side.

**6.** Connect the DC power cord to the power supply, uncoil the AC power cord and then connect it to the AC power source .

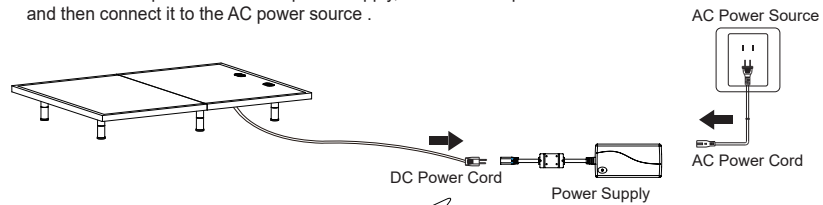

Connect the connectors as illustrated.

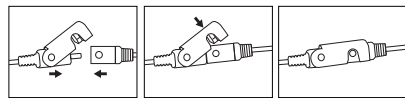

**7.** Insert batteries into the wireless remote.

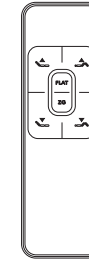
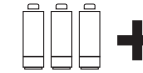

**DONE!**

### Installation Guide (headboard bracket)

**1.**

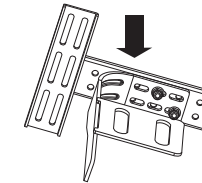
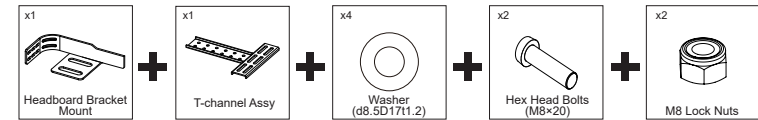

Install headboard brackets with socket screw wrench and simple open end wrench.

**2.**

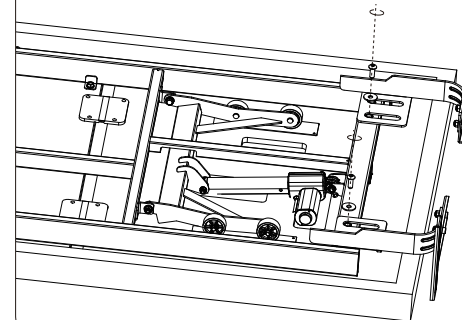

Install the assembled headboard brackets with washers(d10D30t2) and hex socket button head screws(M10x25) onto the end of head frame.

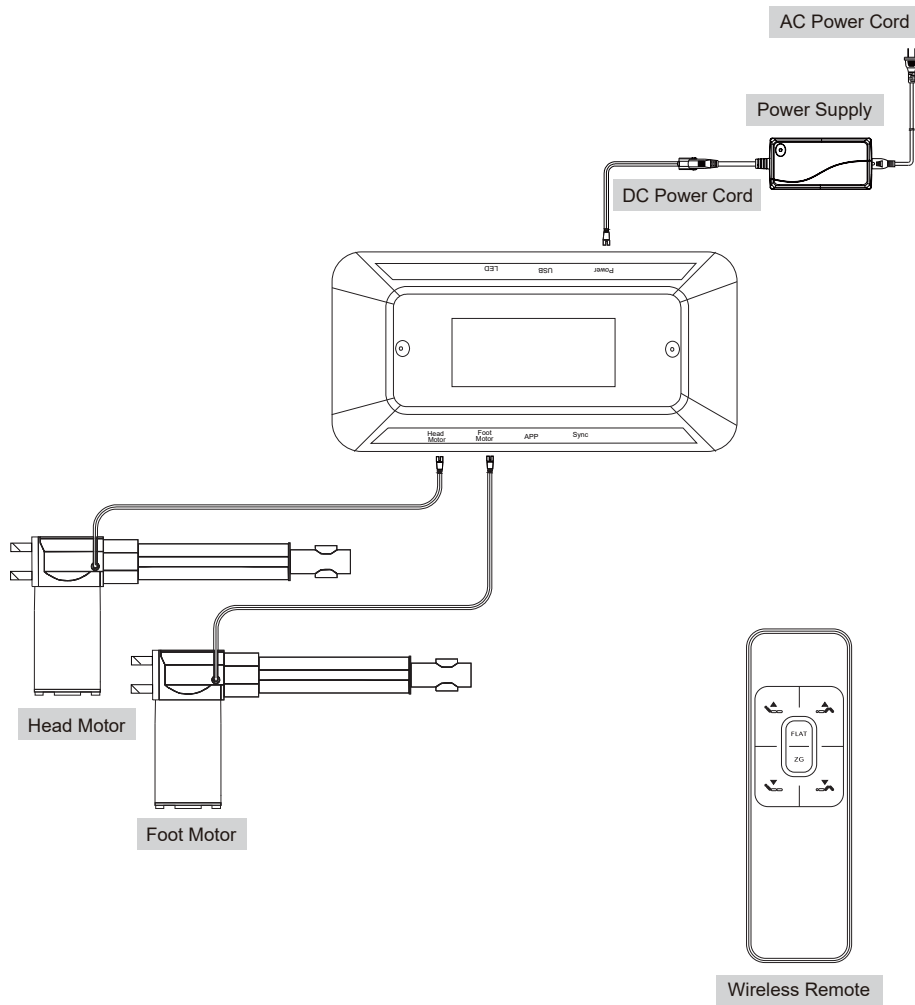

## Synchronizing Two Foundations

If simultaneous operation of two foundations is desired, use the sync cord to connect the electronics of both foundations together. **(single bed only)**

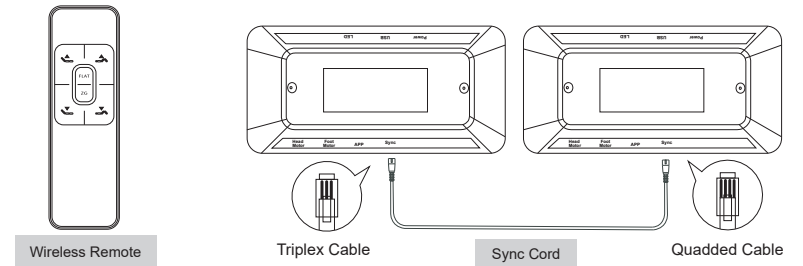

- STEP 1: Unplug foundations from the power source.
  - STEP 2: Connect the male ends of the sync cord to the female sync plugs of the control boxes (Refer to illustration above).
  - STEP 3: Plug foundations back into the power source.
  - STEP 4: Press and hold and button, a beep sound of the buzzer will be heard and the backlit light of the wireless remote flashes twice. Open the battery box and toggle the switch to "P" position (in the middle of "A" and "B") first, next press and hold "FLAT" until you hear a beep sound of each buzzer on the control box, which means the two foundations can be synchronized with one remote.
  - STEP 5: Open the battery box and toggle the switch to "A" or "B" position, you can control the two foundations separately without removing the sync cord.
- Attention: (1) If you want to toggle from "A" or "B" to "P" position (in the middle of "A" and "B") to realize sync control, please press and hold "Flat" again until to a flat position. (2) The interval must more than 4s between plug in and plug out the sync cord.

## Remote Pairing

The original remote that comes in the box is already paired to the foundation. Just wait 30s after the foundation is powered on, then the remote can be used normally. In the event that the remote is not paired with the foundation, follow the steps below.

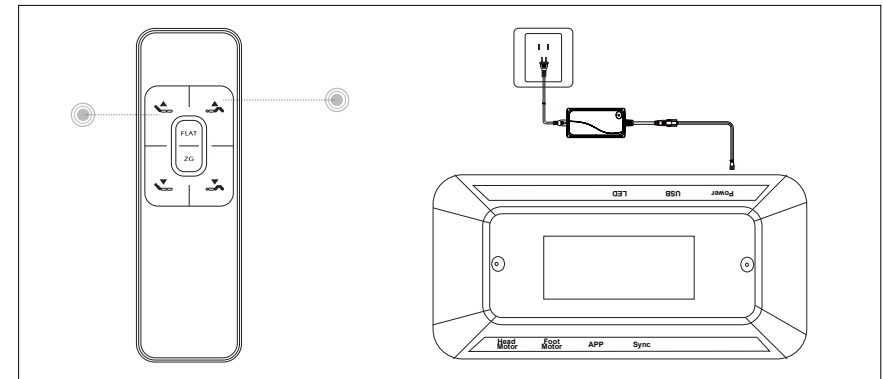

1. Unplug the foundation from the power source, wait 60s, then power it on.
2. Press and hold at the same time.
3. You will hear a beep sound of the buzzer and the backlit light of the wireless remote flashes two times, which means the pairing is successful.

**NOTE: Please complete the repairing within 30s after the foundation is powered on.**

## Remote Control Guide

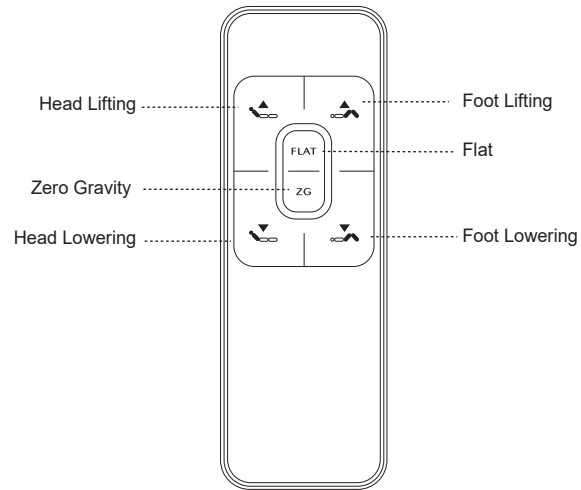

## Adjustment



## One Touch Button

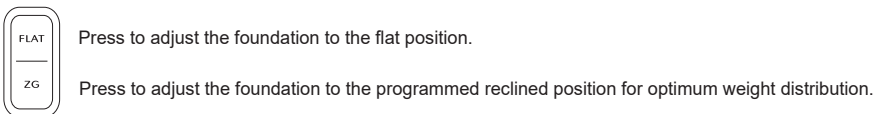

## Battery Lock Wire Installation Guide

When disconnect the power supply, the battery lock wire and two batteries with 9V 2A can be used together to flat the foundation.

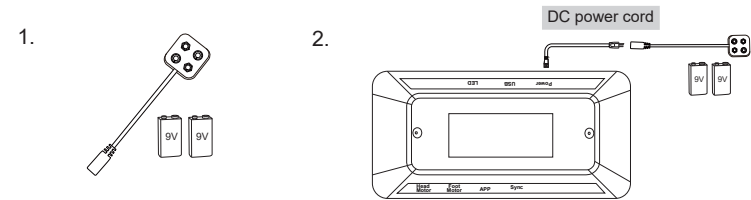

## How To Reset

- STEP 1: Unplug foundations from the power source.
- STEP 2: Plug foundations back into the power source after 60 seconds.
- STEP 3: Automatic reset is completed.

## Dream Motion APP (optional)

The Dream Motion APP is applied to control the foundation, available to both IOS and Android users.

### IOS

Open the APP store, search the keyword "Dream Motion" to download the application.  Dream Motion

### Android

Open the Google Play to search the keyword "Dream Motion" and download the application.  Dream Motion

**Please follow the operation guidance in APP!**

## Troubleshooting

In the event the adjustable foundation fails to operate, investigate the symptoms and possible solutions below.

<p>The adjustable foundation does not respond when the remote is used. Remote control appears to be normal.</p>	<ul style="list-style-type: none"> <li>• Make sure the remote control is paired with the foundation.</li> <li>• Check that the power cord is plugged into a working and grounded electrical outlet. Unplug the power cord from the outlet. After 60 seconds, plug it back in. Press any button on the remote control and hold until backlit light on the wireless remote illuminates.</li> </ul>
<p>No features or function of the foundation activates.</p>	<ul style="list-style-type: none"> <li>• Make sure the wireless remote is paired with the foundation.</li> <li>• Check that the power cord is plugged into a working and grounded electrical outlet. Unplug the power cord from the outlet. After 60 seconds, plug it back in. Press any button on the wireless remote and hold until backlit light on the wireless remote illuminates.</li> <li>• Check that the surge protection device or electrical outlet is not defective. Test the outlet by plugging in another working appliance.</li> </ul>
<p>Head or foot lifts elevate foundation but does not return to flat position.</p>	<ul style="list-style-type: none"> <li>• Your foundation may be obstructed preventing smooth operation. Remove obstructions from around and under the bed.</li> <li>• Check that the head section is not too close to the wall.</li> <li>• If a headboard is installed, check that it is not too close to the edge of the mattress. Make sure there is enough distance between the headboard bracket and the mattress.</li> </ul>
<p>Head or foot lift function has minor interference during operation.</p>	<ul style="list-style-type: none"> <li>• Check the batteries in the wireless remote. Replace with new batteries, if necessary.</li> <li>• Make sure that you are following the duty cycle of the motors. Do not operate for more than two minutes over a 20-minute period or approximately 10% duty cycle.</li> <li>• Press the lift buttons firmly and accurately.</li> <li>• Wireless remote control may be experiencing common radio frequency interference from other radio transmitting devices. Wait several seconds and then try pressing the lift buttons again.</li> </ul>
<p>A clicking noise is heard under the foundation when raising or lowering the sections.</p>	<ul style="list-style-type: none"> <li>• This is normal. The lift motors click when they are engaged. No action is required.</li> </ul>

# 10 Year Warranty

## 1-Year Parts and Labor Warranty

For the first year from the Warranty Commencement Date, your adjustable base is warranted against non-excluded defects in Dreamotion's workmanship or materials. During the first year from the Warranty Commencement Date, Dreamotion will repair or replace any defective adjustable base part at no cost, and Dreamotion will pay all authorized labor and transportation costs associated with the repair or replacement of any parts found to be defective. This warranty does not apply to Dreamotion adjustable base floor models.

## 5-Year Motor Warranty

For the five year from the Warranty Commencement Date, Dreamotion will offer replacement parts for any defective parts to the purchaser, including factory supplied electronics, electrical components, drive motors and power supply components. You are responsible to pay all service and transportation costs related to the costs of receiving and installation of the new part. This warranty does not apply to Dreamotion adjustable base floor models.

## 10-Year Frame Warranty

Notwithstanding the above, Dreamotion extends a 10-year warranty on the frame itself used in the product. Specifically, Dreamotion warrants that for a full 10 years from the commencement date of the warranty, any defect in the workmanship or the materials used in the frame itself shall be covered. The 10-year time span will be dated from the date of purchase to the original Purchaser. For purpose of the 10-year warranty, the frame consists of metal structure of the base and specially excludes its cover, side rails, platform, legs, actuators, massage motors, control box, remote controls, USB, power supply, and any power supply cords. Return of the frame should it need to be replaced, is not required. The purchaser shall pay 1/96 of the current MSRP of the replacement part, or the entire adjustable base if deemed irreparable at the sole discretion of the manufacturer, multiplied by the number of months after the second year from the original purchase date. The manufacturer's liability shall be limited to the replacement of the defective part(s) ONLY with the purchaser responsible for all service, installation and freight costs for said part. This warranty does not apply to Dreamotion adjustable base floor models.

## ADDITIONAL TERMS AND CONDITIONS

---

This warranty shall be void in the following circumstances:

1. Any damage caused by customer.
2. Damage caused by repair or replacement of adjustable parts by any unauthorized technician or person.
3. Damage caused if the adjustable base has been mishandled (whether in transit or by other means), subject to physical or electrical abuse or misuse, or otherwise operated in any manner inconsistent with the operation and maintenance procedures outlined in the Owner's Manual and this warranty.
4. Damaged mattresses, fabric, cables, electrical cords or items supplied by dealers or any third party. Contact your dealer for warranty information on these items.
5. Any modification of the adjustable base after purchase.
6. Any costs for unnecessary service calls, including costs for in-home service calls for the purpose of educating the consumer or finding a proper power connection.
7. If the recommended weight restriction is not followed.
8. Neither will this warranty cover any purchaser other than the original purchaser, nor will it cover product purchased from an unauthorized third party.
9. This warranty requires notice to be given to Dreamotion of any claim for repairs or replacement parts.

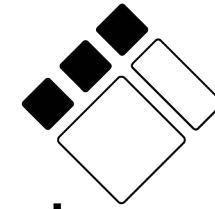

**back to sleep**<sup>®</sup>  
the bedding & mobility specialists

Back to sleep  
313-315 Whitehorse Road  
Balwyn VIC 3103  
Tel: 1300 848 077  
w: [backtosleep.com.au](http://backtosleep.com.au)  
e: [info@backtosleep.com.au](mailto:info@backtosleep.com.au)